



## Constant Power Emergency LED Driver



Project: \_\_\_\_\_

Catalog # \_\_\_\_\_

Type: \_\_\_\_\_

Date: \_\_\_\_\_

### Product Features

- UL Listed for field or factory installation.
- Constant output power(Auto-sensing output within each range)
- Safe, low voltage Class 2 output.
- Self-Test automatically per month/year
- Provides emergency lighting for a minimum of 90 minutes
- Universal input:100-277Vac, 50/60Hz
- 2-in 1 design test switch/indicator light
- Low energy charger (CEC Title 20 compliant)
- RoHS compliant
- 5-Year Warranty

### Typical Applications

- Suitable for LED module designed to accept any constant input current of 310 - 600mA and has a forward voltage range of 25 - 48VDC.
- Ideal for LED linear strip, architectural light, vapor tight and other fixtures



### Product Certification



### Product Specifications

Input Voltage	100-277 VAC, 50/60Hz	Output Voltage	25-48 VDC
Input Current(Max.)	100mA	Output Current	310-600mA
Input Power(Max.)	7.0W	Output Power	15W
Emergency Time	°90 minut es	Battery Type	Lithium ion battery
Recharge Time	°24 hours	Ambient Temp	5°C to +50°C (41°F to 122°F)

## Ordering Information

Model No.	Input Voltage	Emergency Power	Emergency Time
EMG-2G-15W	100-277V AC	15W	90 minutes

## Packaging

Net Weight	Gross Weight	Master Pack Qty	Master Pack Size
15.3KG	15.8KG	30PCS	480 x 230 x 245mm

## Dimensions

**Housing:** L7.4"xW1.5"xH1.14"(188mmx38mmx29mm)

**Mounting center - 7.0"**

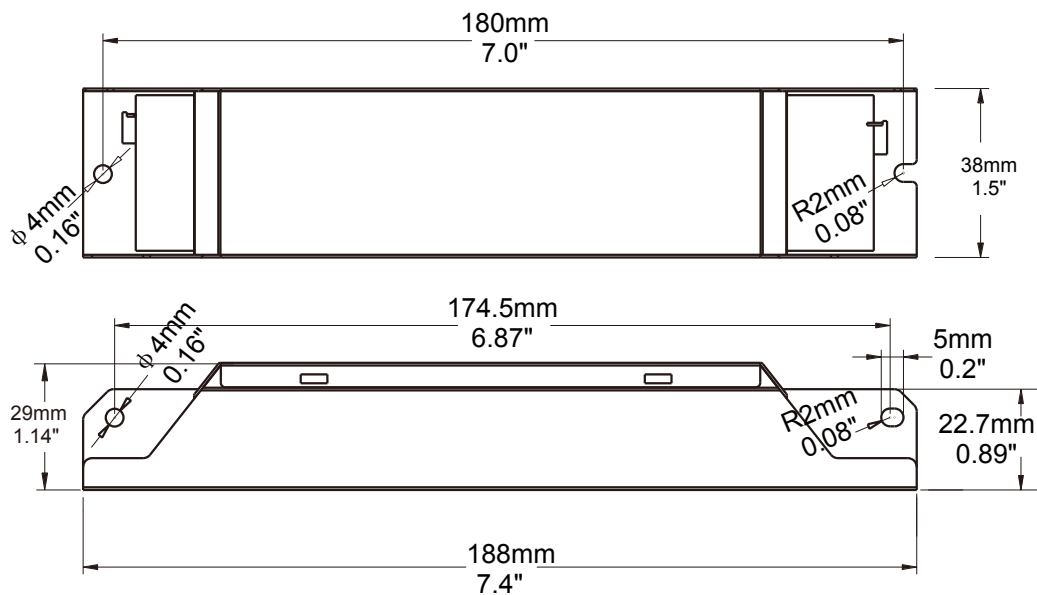

**Battery pack:** L6.55"xW1.6xH1.17" (166.4mmx40.6mmx29.66mm)

**Mounting center - 5.86"**

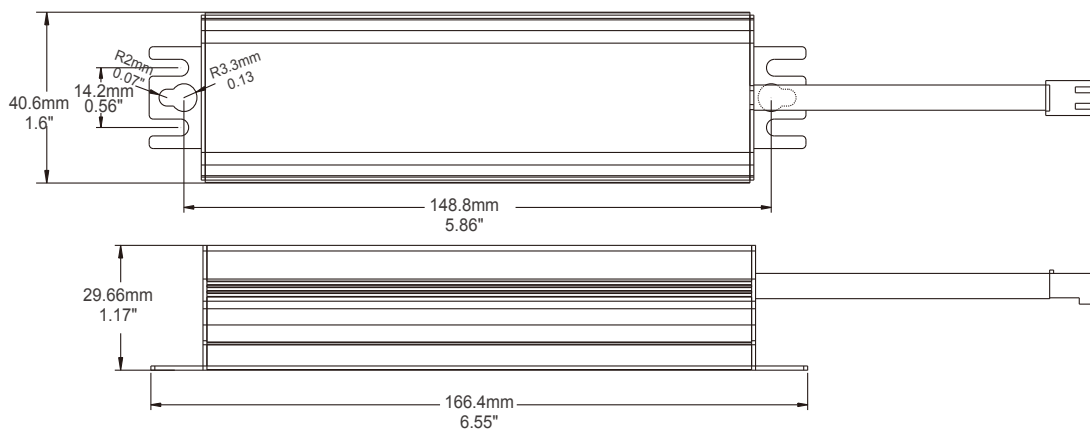

Product includes the following components:

PARTS	QUANTITY
LED Emergency Driver	1
Charging Indicator/Testing Button	1
Instruction Sheet	1

## Typical Wiring Diagram



**WARNING DISCONNECT POWER BEFORE INSTALLING OR SERVICING.**

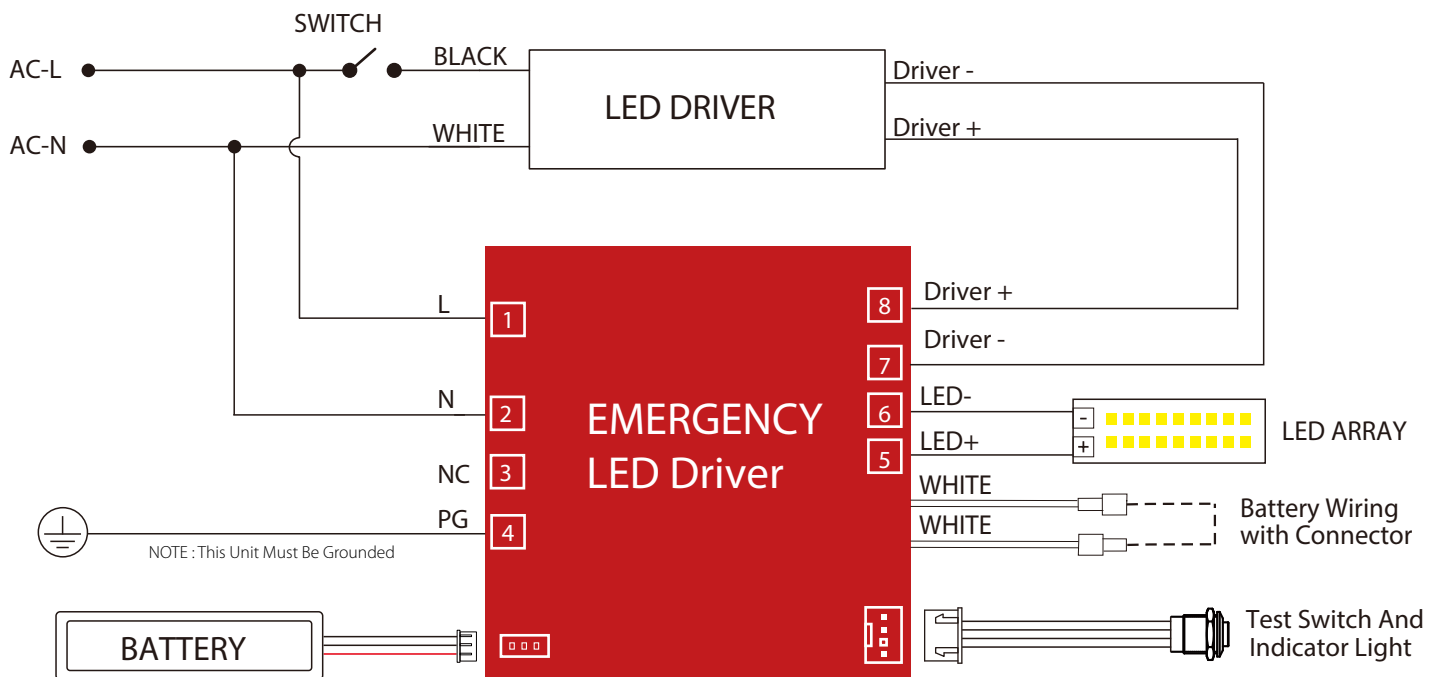

### Note:

1. DO NOT MATE CONNECTOR UNTIL INSTALLATION IS COMPLETE AND AC POWER IS SUPPLIED.
2. TEST ACCESSORY LEADS-OBSERVE PROPER POLARITY WIRING.
3. For short-term testing of the emergency function, the battery must be charged for at least one hour. The emergency driver must be charged for at least 24 hours before conducting a long-term test.