

WCEM-2

Project Name:	
Type:	



APPLICATION

Ideal for commercial where economy, appearance and the ultimate ease of installation and maintenance are desired. LED compact and decorative design Edge-Lite exit sign series utilizes a unique illumination design in an architecturally aluminum housing.

FEATURES:

- Ideal for wet location / outdoor commercial and industrial facilities where economy, appearance and the ultimate ease of installation and maintenance are desired. Solid state electronics offer both reliability and low-cost performance.
- Injection-molded, engineering-grade, V-0 flame retardant, high-impact, polycarbonate housing.
- Compact, low-profile design, fully-gasket polycarbonate enclosure provided resistance to corrosive atmospheres and non-hazardous environments.
- Adjustable eyeball 6V, 7W MR16 halogen two lamp heads.
- 90+ minute emergency operation.
- Available in light gray housing.

MOUNTING:

- Universal knockout pattern on back plate for wall mount. Snaps into place making internal electrical connections.

ELECTRICAL:

- 120/277V dual voltage operation standard.
- Charge rate/power "ON" LED indicator light and push-to-test switch for mandated code compliance testing.
- LVD (Low Voltage Disconnect) prevents battery from deep discharge.

LAMPS:

- Two fully adjustable semi-recessed, round MR16 lamp heads for optimal light distribution.
- Ultra-bright, energy efficient, long-life White LED lamps provide up to 76-ft center-to-center spacing with 3-ft path of egress at 7.5-ft mounting height.

BATTERY:

- 6V 4.5Ah, maintenance-free, sealed lead acid rechargeable battery on emergency (EM) units.
- Fully automatic solid-state, two-rate charger initiates battery charging to recharge a discharged battery in 24 hours.
- Internal solid-state transfer switch automatically connects the internal battery to LEDs for minimum 90 minute emergency illumination.

OPTION:

- HTR : Using the internal heater enables the unit to be used in cold environments.

LISTING:

- 5 years limited warranty on materials and all electronics. Battery pro rated for two years.
- UL listed for wet locations & meets UL924, National Electrical Code, ANSI /NFPA 70 and the Life Safety Code ANSI/NFPA 101.
- ARRA and BAA compliant (optional).
- NFPA 70 compliant.

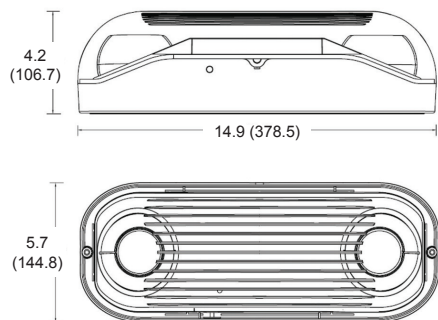

Dimensions

- A: Housing Width: 14.9 (378.5)
- B: Housing Height: 4.2 (106.7)
- C: Housing Depth: 5.7 (144.8)

All dimensions are in inches (millimeters).

ORDERING INFORMATION

EXAMPLE: WCEM-2

MODEL	LAMP		HOUSING COLOR		OPTIONS	
WCEM-2	PLED	7.0W High Lumen White LED Lamps standard	GR BK	Light Gray Black	HTR BAA	Internal Heater Buy American Act compliant